

AIRGON₂

The fastest way to reduce your heating bill by up to 20%

How Airgon reduces running costs for Biomass heating systems

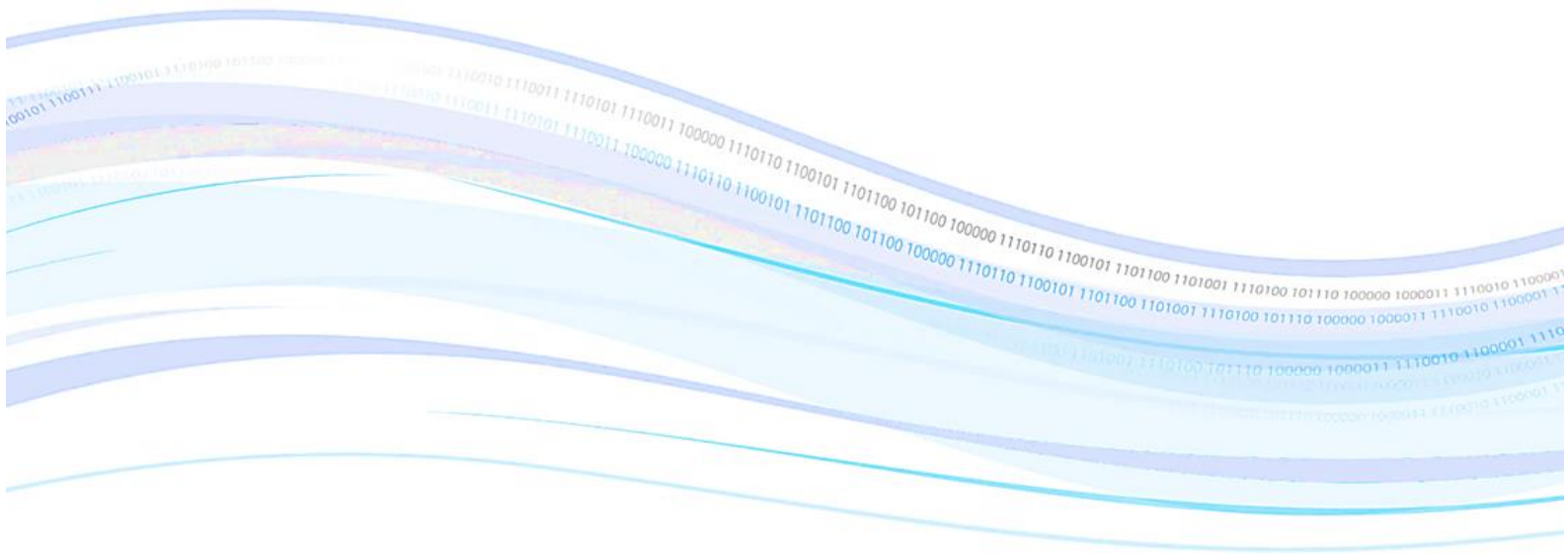

How Airgon reduces running costs for Biomass heating systems.

What is a biomass central heating system?



Biomass heating systems burn wood pellets, chips or logs to provide warmth in a single room or to power central heating and hot water boilers.

A biomass burner used for space heating is typically fuelled by premium grade pellets. These pellets can be fed manually or automatically by a hopper into the burner, which takes the place of a gas or oil boiler that is most commonly used to provide heat for water. The pellet burner heats water passed over the burning pellets and is usually fed into a dual circuit holding tank that feeds both the radiators and domestic hot water.

Not all biomass systems employ a holding tank. The water in the tank is used similarly to a flywheel on a generator. It helps to maintain water temperature when the desired levels have been reached, which can reduce fuel consumption under heavy use.

The rest of the heating system is identical any gas or oil based wet heating system employing radiators and therefore suffers from the same issues concerning water based gases that reduce heat transfer and cause corrosion.

Airgon typically reduces energy input by around 18% but each system is different and in some cases it can be higher than 25%. This is due to its ability to improve thermal transfer. Many biomass burners have a choice of fuel options:

1. Wood chips: are a popular biomass fuel for heating systems. They have a moderate heat output and burn relatively slowly, making them suitable for use in boilers and furnaces. Wood chips have a moisture content of around 30-50%, which can impact their heat output and efficiency.
2. Wood pellets: are compressed sawdust and other wood waste materials, which have a higher energy density than wood chips. They burn hotter and more efficiently than wood chips, making them ideal for use in small-scale heating systems, such as pellet stoves and boilers. Wood pellets have a lower moisture content than wood chips, typically around 10-12%.
3. Straw: is a low-cost biomass fuel that can be used for heating. It has a low energy density and a low moisture content, which means it burns quickly and produces less heat than other biomass fuels. Straw is suitable for use in boilers and furnaces, but may not be efficient enough for smaller heating systems.

4. Miscanthus: is a type of grass that can be used as a biomass fuel. It has a high energy density and low moisture content, making it an efficient fuel for heating systems. Miscanthus burns hotter and longer than other biomass fuels, making it suitable for use in larger boilers and furnaces.
5. Pelletized agricultural residues: Pelletized agricultural residues, such as corn cobs and wheat straw, are a low-cost biomass fuel that can be used for heating. They have a moderate heat output and burn relatively slowly, making them suitable for use in boilers and furnaces. Pelletized agricultural residues have a low moisture content, typically around 10-12%.

The heat profile of biomass fuels can vary widely depending on the type of biomass and its moisture content. Wood pellets and miscanthus tend to have higher energy densities and burn more efficiently, making them suitable for smaller heating systems, while wood chips and pelletized agricultural residues may be better suited for larger boilers and furnaces.

This report will primarily focus on those systems employing wood pellets as these are the most commonly used fuel in the environments that are going to benefit most from fitting either an Airgon A22 or an Airgon A54.

Wood pellets are generally sold in 6mm compressed form at various levels of energy density depending upon the materials used to form them and the standard looking to be achieved.

A simple cost per energy output comparison would be;

Product	Cost per MT	Cost per kg	Energy Output (kwh/kg)	Cost / Kwh
Hardwood Pellets	£940	£9.40	5.3	£1.77
Premium Pellets	£810	£8.10	4.1	£1.98
Economy Pellets	£533	£5.33	3.5	£1.52

Costs are presented as at April 2023 Source?

On the basis that the thermal output from a biomass-based boiler is adjustable by using alternative pellets, it is possible to achieve the desired heating profile using cheaper fuels because Airgon is able to more efficiently apply the heat derived.

For a typical home, 4.5m³ is the approximate amount consumed over the course of a year. This does not need to be purchased at once and is generally divided in to 3 or 4 deliveries.

Wood Pellets typically weigh around 650kg per cubic meter, so the total amount in this example is around 2.9MT. This equates to an annual energy requirement of 11,890 kW/h, which is in keeping with the amount of energy expected to be consumed annually by a gas boiler heating a 3-bedroom home.

As can be seen from the table above, 2.9MT would usually cost £2,349 if premium pellets are used, and £1,545 if standard pellets are purchased. These figures are applied prior to the installation of Airgon, to which we will assume an average 18% reduction in input energy can be achieved.

Post Airgon installation, the energy consumption for this example reduces to 9,749 kW/h annually. This translates to a reduction in pellet costs to £1,926, a saving of £423 a year.

Because Airgon improves the thermal transfer, we can also further reduce the fuel cost by changing to the lower grade pellets. If we calculate the cost of using standard pellets rather than premium, the cost to generate 9,749 kW/h would be £1,484 annually, achieving an additional fuel saving of around £442 a year in addition to the £423 a year already recovered from the premium pellet cost. Saving £865 each year.

Wood chips can provide an even cheaper cost per kW/h and commensurate savings will be achieved if switching from a more expensive biofuel source. In many industrial applications, wood chip is the fuel of choice due to its low cost and the availability of storage.

Wood chip is bulkier than pellets. Airgon will still perform well with wood chip used in burners, as the improvement is made to the system's ability to transfer heat. The water used to conduct heat is able to do so more efficiently, and so we would expect to see savings of around 18% to 23% on wood chip based heating systems, just as we would with pellets or other fuel sources.

CONCLUSION

By installing Airgon it is possible to reduce the fuel cost of running a Biomass heating system from a typical £2,349 per year, to £1,484, saving £865 per year or a huge 38% by improved efficiency facilitating the use of lower cost pellets.

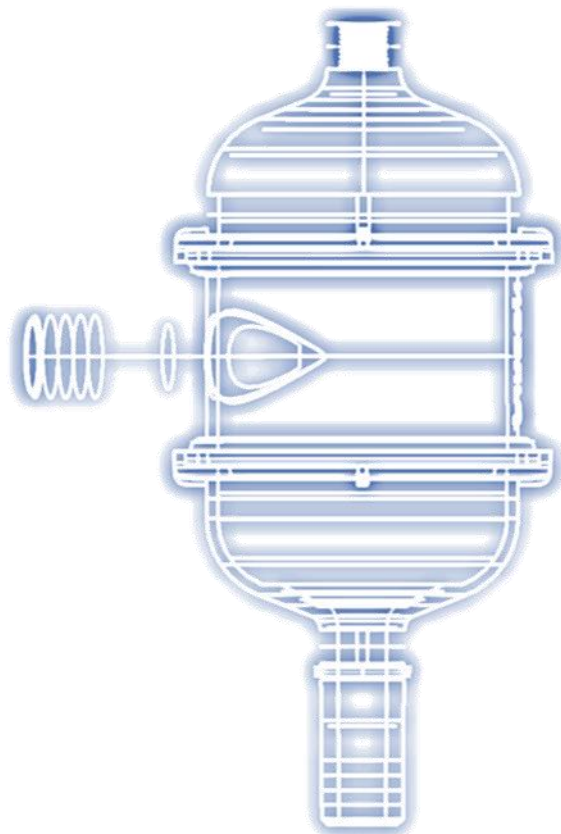

www.airgon.co.uk



Report Number: 2023_274.
NEL Ref: AIG001.